

## P-Series Inclinometer

# Instruction Manual

## Single and Dual Axis Inclinometer

### P-Series

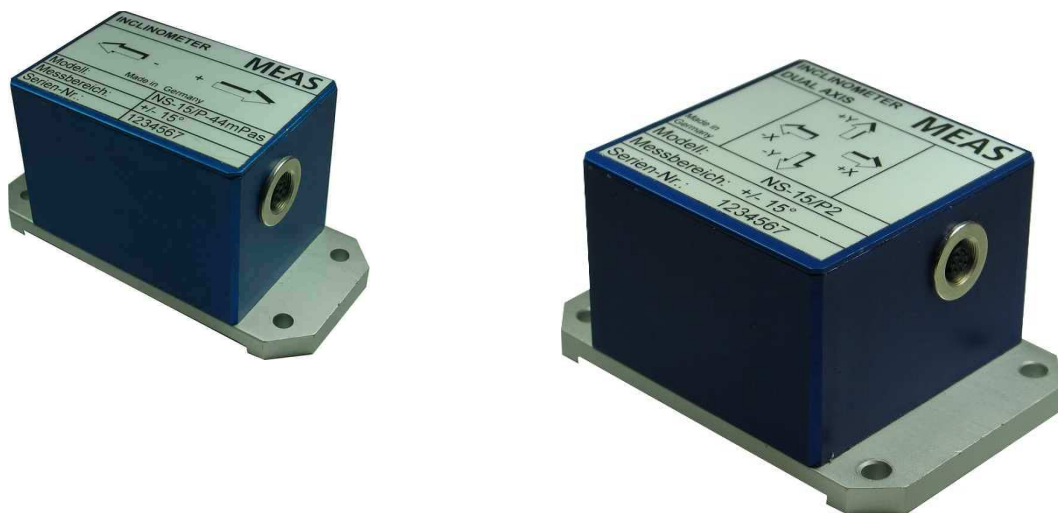

Version 1.2

**P-Series Inclinometer**

**Table of Contents**

1	Introduction .....	3
2	Notice .....	3
3	History .....	3
4	General of the inclinometer system .....	4
4.1	Description of the liquid/conductive measurement principle .....	4
4.2	Ordering information .....	5
4.3	Electrical Connection .....	6
4.4	Cable/Connector Assembly (optional) .....	6
5	Dimensions / Mounting/ Electrical Connections .....	7
5.1	Dimensions [mm] of the Dual Axis Unit .....	7
5.2	Dimensions [mm] of the Single Axis Unit .....	8
5.3	Mounting Instruction .....	9
5.4	Installation .....	9
5.5	Measurement Direction .....	9
5.6	Absolute Maximum Ratings .....	10
5.7	Electrical Connections .....	11
5.7.1	Pinning single axis unit with RS 232 / voltage output signal: NS-5/P, NS-15/P, NS-45/P .....	11
5.7.2	Pinning single axis unit with RS 232 / current output signal: NS-5/PI, NS-15/PI, NS-45/PI .....	12
5.7.3	Pinning dual axis unit with RS232 output signal: NS-5/P2, NS-15/P2, NS-45/P2 .....	13
5.7.4	Connection Digital Interface RS 232 .....	13
5.8	Programming Instructions .....	14
5.8.1	Commands in user level .....	14
6	Packaging for Delivery .....	16

## P-Series Inclinometer

### 1 Introduction

Thank you for purchase of a P-Series inclinometer from Measurement Specialties. This manual offers information on the proper installation and operation.

### 2 Notice



Please observe all proper safety rules and regulations for electrical devices when installing this inclinometer. In addition, the following recommendations are made.

1. Do not apply power to the inclinometer during installation.
2. Avoid applying any mechanical pressure or stress to the housing.
3. Do not operate an inclinometer beyond the maximum angular sensing range or threshold. Irreparable damage may occur.
4. Do not exceed the maximum fastening torque for the mounting screws, as the base plate may become warped and/or irreparably damaged.
5. Use detergents free of alcohol or acid for cleaning of the housing.
6. Avoid direct solar radiation.
7. Hand tightens mating connector. DO NOT use pliers as damage may occur.
8. Should the inclinometer fail to operate properly, consult this manual for possible solution. Do not attempt to open the inclinometer, as damage may occur. For other troubleshooting measures, please contact our customer service team.

### 3 History

Version	Date	Treatment	Author
1.0	05.Dec. 2011	First Draft	M.Zürn
1.1	20.Nov. 2013	Correction 5.6.1.1 graph	M.Zürn
1.2	28.Sep. 2016	Update maximum ratings, Layout	M.Zürn

## P-Series Inclinometer

### 4 General of the inclinometer system

#### 4.1 Description of the liquid/conductive measurement principle

Platinum electrodes are deposited in pairs on the base of the sensor's cell parallel to the sensitive axis. The chamber is partially filled with an electrolytic liquid. When an alternating voltage is passed between two electrodes, the electric current will create a dispersed field. By tilting the sensor and thereby reducing the level of liquid, it is possible to confine this stray field. Because of the constant, specific conductivity of the electrolytes a variance of resistance is formed in relation to the liquid level. A basic differential principle will yield an angle of inclination from the polarity signs.

Ceramic housing

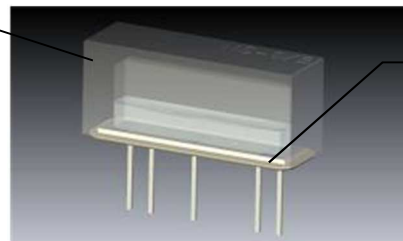

Ceramic base plate with electrodes

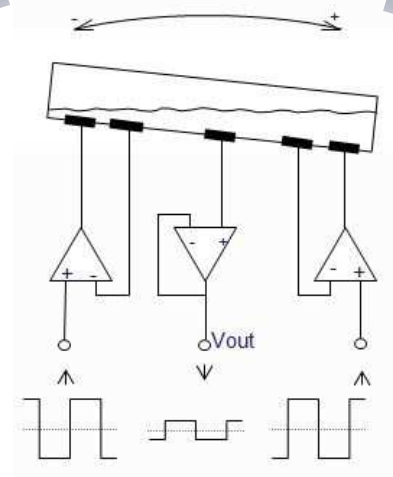
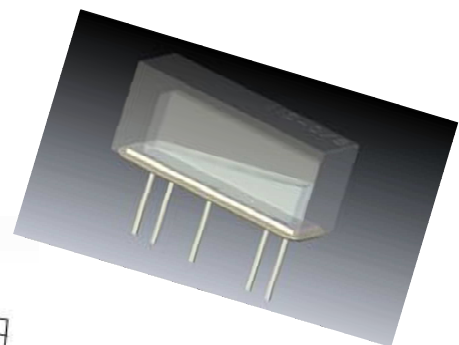
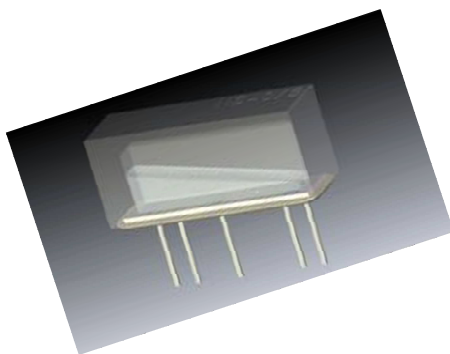

## P-Series Inclinometer

### 4.2 Ordering information

TE Connectivity Sensors offers single and dual axis inclinometers of the P-series in the three different measurement ranges +/- 5°, +/- 15° and +/-45° with RS 232, voltage or current output signals.

PART NUMBERING	UNIT	SHORT DESCRIPTION
<b>Single axis unit</b>		
G-NSP-001	NS-5/P	single axis, +/-5° angle, Vcc + 6.5...24VDC, output +/-1.5V,RS232
G-NSPI-001	NS-5/PI	single axis, +/-5° angle, Vcc + 6.5...24VDC, output 4...20mA,RS232
G-NSP-002	NS-15/P	single axis, +/-15° angle, Vcc + 6.5...24VDC, output +/-1.5V,RS232
G-NSPI-002	NS-15/PI	single axis, +/-15° angle, Vcc + 6.5...24VDC, output 4...20mA,RS232
G-NSP-005	NS-45/P	single axis, +/-45° angle, Vcc + 6.5...24VDC, output +/-1.5V,RS232
G-NSPI-006	NS-45/PI	single axis, +/-45° angle, Vcc + 6.5...24VDC, output 4...20mA,RS232
<b>Dual axis unit</b>		
G-NSP2-001	NS-5/P2	dual axis, +/-5° angle, Vcc + 6.5...24VDC, output RS232
G-NSP2-003	NS-15/P2	dual axis, +/-15° angle, Vcc + 6.5...24VDC, output RS232
G-NSP2-006	NS-45/P2	dual axis, +/-45° angle, Vcc + 6.5...24VDC, output RS232
<b>Accessories</b>		
G-NSMIS-005	certificate	certificate of calibration, calibration protocol
G-NSMIS-001	connection	connector, straight, Submin. 712-series
G-NSMIS-015	connection	connector, angle 90°, Submin. 712-series
G-NSMIS-002	connection	2 m cable, straight connector Submin. 702-series
G-NSMIS-003	connection	2 m cable, angle 90° connector Submin. 702-series

Other cable length on request

## P-Series Inclinometer

### 4.3 Electrical Connection

- 7 pin male socket. Manufacturer = 'Binder – Connectors', type 712, M9 x 0.5

### 4.4 Cable/Connector Assembly (optional)

Type of cable: LiYCY 6 x 0.14mm<sup>2</sup>  
 Conductor resistance: 131 Ohm/km  
 Capacity: 90pF/m at 1kHz  
 Length: 2m (further lengths on request)  
 Connector: 712-series (M9 x 0.5)

- Straight connector, order-no.: G-NSMIS-002
- Angle (90°) connector, order-no.: G-NSMIS-003

- **Connector only (optional)**

- Straight connector, order-no.: G-NSMIS-001

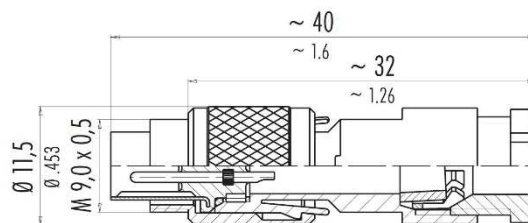

Fig. 4.4.1 Connector drawing , straight

- Angle 90° connector, order-no.: G-NSMIS-015

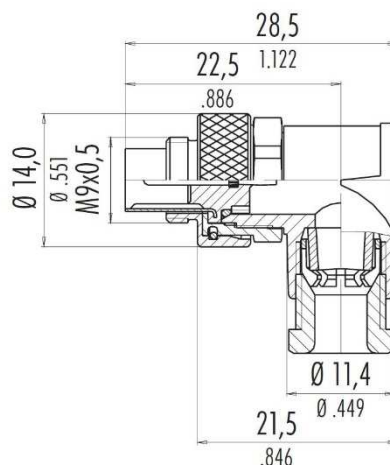

Fig. 4.4.2 Connector drawing , angle 90°

P-Series Inclinometer

5 Dimensions / Mounting/ Electrical Connections

5.1 Dimensions [mm] of the Dual Axis Unit

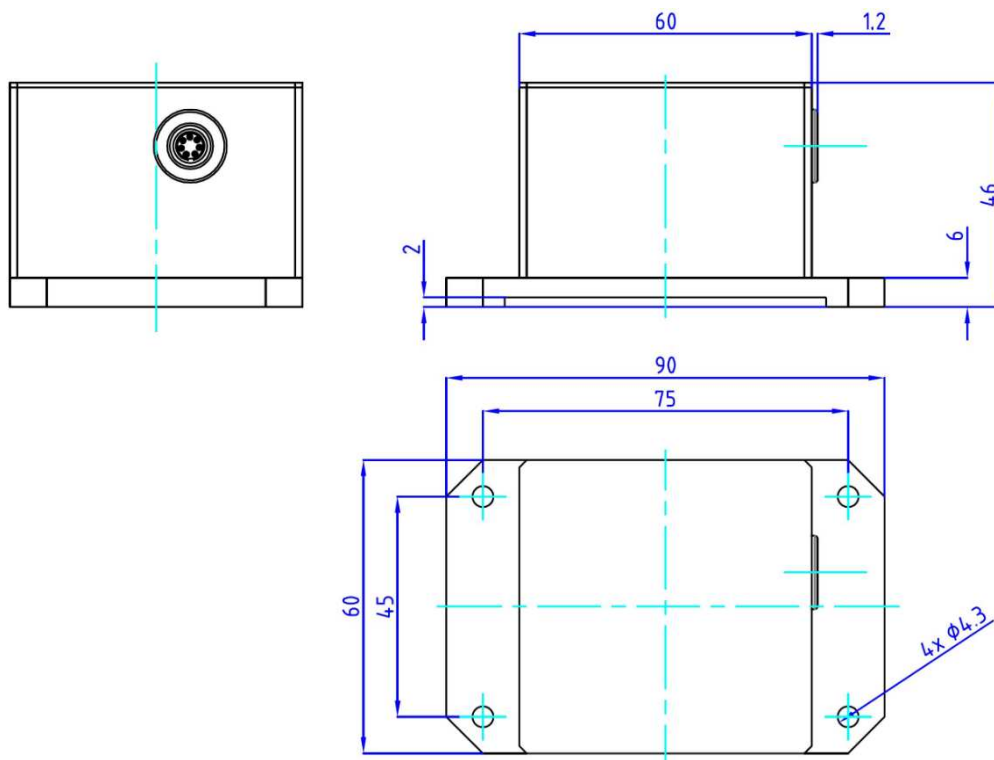

Fig. 5.1.1 View of the dual axis inclinometer housing and connector

## P-Series Inclinometer

### 5.2 Dimensions [mm] of the Single Axis Unit

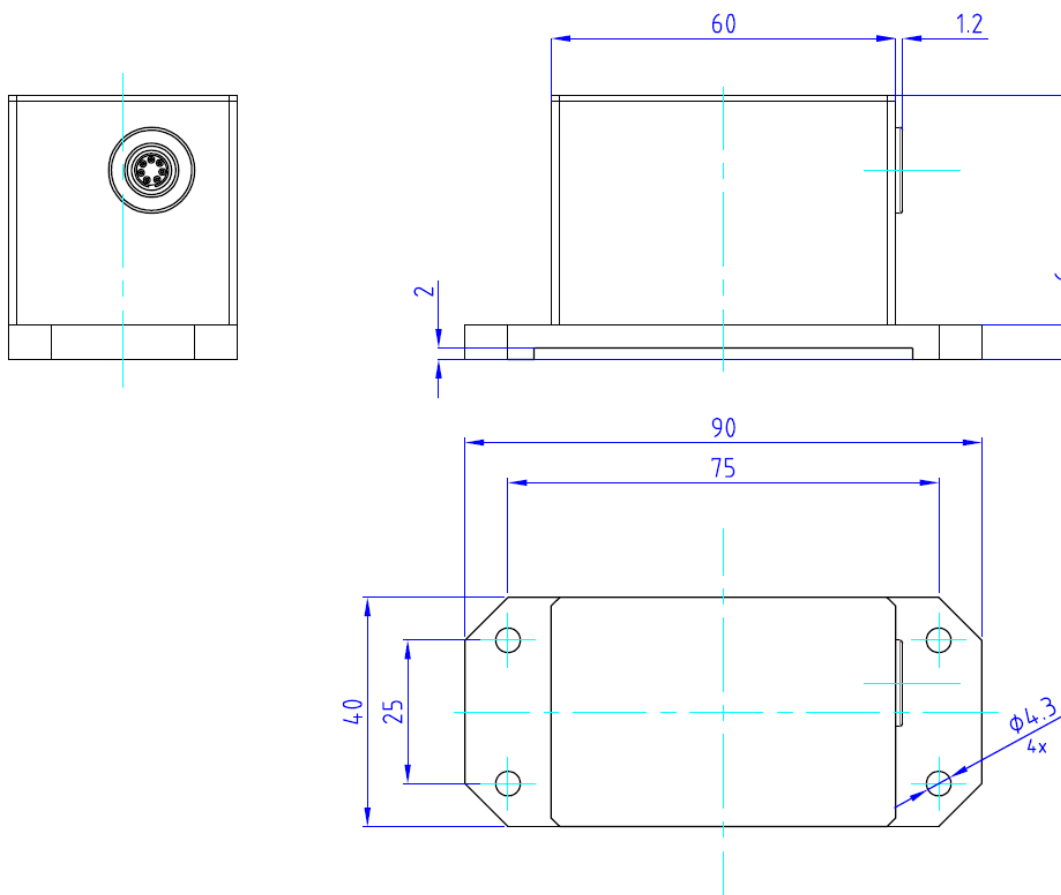

Fig. 5.2.1 View of the single axis inclinometer housing and connector



## P-Series Inclinometer

### 5.3 Mounting Instruction

The inclinometer is designed for horizontal mounting, meaning the base plate of the inclinometer with the four mounting holes needs to be placed on the horizontal plane of the object to be measured. The mounting surface must be smooth and free of dust and grease. Fasten inclinometer to the surface to be measured using three #M4 screws, and torque to a maximum of 10 Nm (do not exceed!!).

### 5.4 Installation

Prior to installation, please check for all connection and mounting instructions to be complied with. Please also observe the general rules and regulations on low voltage technical devices.

Avoid shock and vibration during measurement, as these could adulterate the measurement results. Inclination sensors that base on a fluidic measurement principle are optimal for static measurements and suitable to only a limited extent of dynamic measurement.

### 5.5 Measurement Direction

Tilt angle measurements are made in the 'X' and 'Y' axis' (longitudinal and lateral respectively), with the reference being the horizontal plane.

For **single axis** units the longitudinal axis 'X' is valid only.

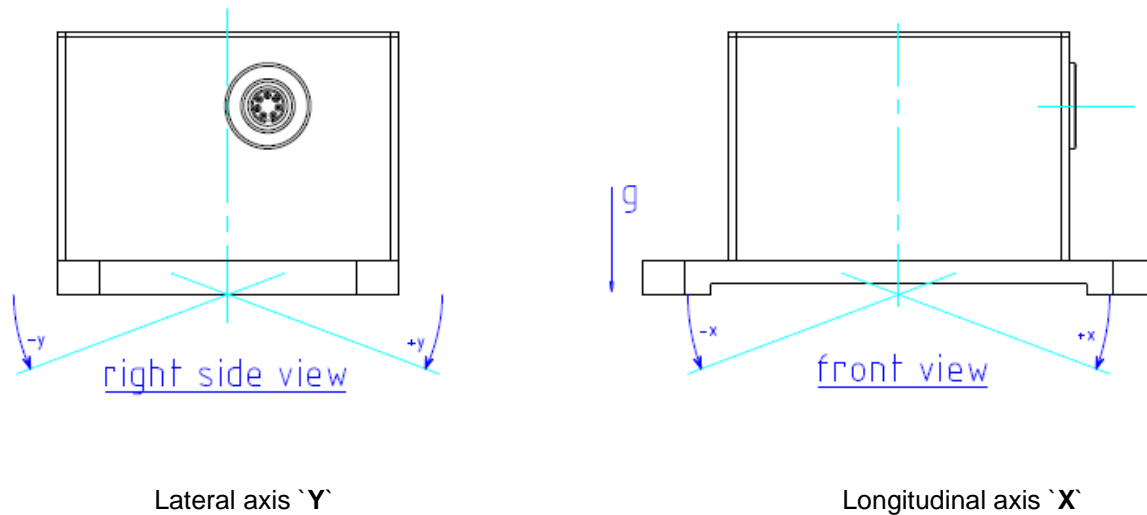

Fig. 5.5.1 X and Y axis identification

## P-Series Inclinometer

### 5.6 Absolute Maximum Ratings

Parameter	Symbol	Conditions	Min	Typ	Max	Unit
Power supply	+Vcc	Measured +Ub to GND, No polarity protection	0		+28	V
Maximum angle	$\phi_{max}$	NS - 5/Px NS - 15/Px NS - 45/Px Do not exceed maximum angle while under power supply for extended period of time. Irreversible drift may occur.	-15 -40 +60		+15 +40 +60	° ° °
Storage temperature	Tstor		-25		+85	°C
Operation temperature	Ta		-25		+85	°C

## P-Series Inclinometer

### 5.7 Electrical Connections

#### 5.7.1 Pinning single axis unit with RS 232 / voltage output signal: NS-5/P, NS-15/P, NS-45/P

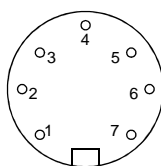

Pin	Name	Description	Type	Color schema <sup>(1)</sup>
1	Vcc	power supply +6.5...+24VDC	supply	white
2	GND	power supply ground, RS 232 ground	supply	brown
3	Earth	earth	supply	green
4	GNDx	signal ground for voltage output	supply	yellow
5	Out x	x-axis voltage output +/-1.5V	output	grey
6	RxD	input digital signal RS232	input	pink
7	TxD	output digital signal RS 232	output	blue

(1) by using a TE Connectivity Sensors cable

Typical curve of voltage output signal +/-1.5 V in reference to signal **GNDx** of an inclinometer NS-5/P.

**Notice !** The signal ground **GNDx** has **not** the same potential like the power ground **GND**.

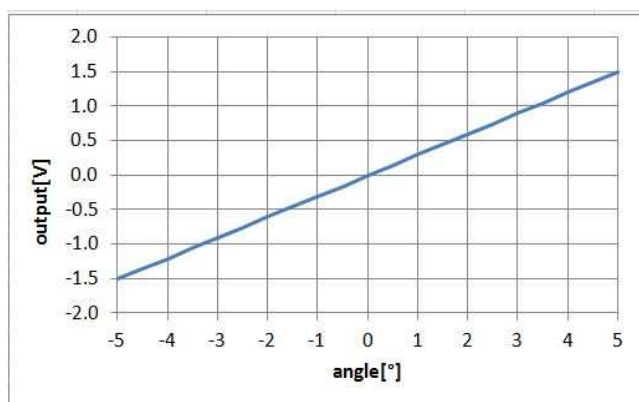
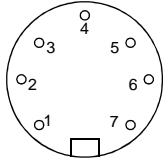

Fig. 5.6.1.1 X-output [V] vs. angle [°]

## P-Series Inclinometer

### 5.7.2 Pinning single axis unit with RS 232 / current output signal: NS-5/PI, NS-15/PI, NS-45/PI



Pin	Name	Description	Type	Color schema <sup>(1)</sup>
1	Vcc	power supply +6.5...+24VDC	supply	white
2	GND	power supply ground, RS 232 ground	supply	brown
3	Earth	earth	supply	green
4	GNDx	signal ground for current output	supply	yellow
5	Out x	x-axis current output 4...20mA	output	grey
6	RxD	input digital signal RS232	input	pink
7	TxD	output digital signal RS 232	output	blue

(1) by using a TE Connectivity Sensors cable

Typical curve of current x output signal 4...20mA in reference to the signal ground **GNDx** of an inclinometer NS-5/PI.

**Notice!** The signal ground **GNDx** has the same potential like power ground **GND**.  
 Measurement range -x (20mA) ... 0° (~12mA) ... +x (4 mA)  
 Standard impedance  $Z_a < 160 \text{ Ohm}$ , special impedance  $Z_a < 260 \text{ Ohm}$  on request

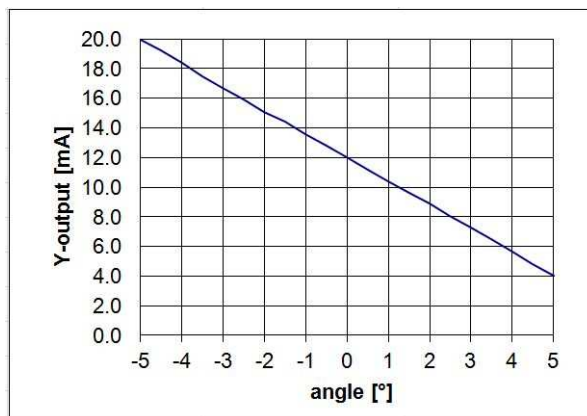
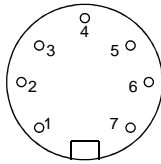

Fig. 5.6.1.1 X.output [mA] vs. angle [°]

## P-Series Inclinometer

### 5.7.3 Pinning dual axis unit with RS232 output signal: NS-5/P2, NS-15/P2, NS-45/P2



Pin	Name	Description	Type	Color schema <sup>(1)</sup>
1	Vcc	power supply +6.5...+24VDC	supply	white
2	GND	power supply ground, RS 232 ground	supply	brown
3	Earth	earth	supply	green
4	n.c.	n.c.	-	yellow
5	n.c.	n.c.	-	grey
6	RxD	input digital signal RS232	input	pink
7	TxD	output digital signal RS 232	output	blue

(1) by using a TE Connectivity Sensors cable

### 5.7.4 Connection Digital Interface RS 232

#### 5.7.4.1 Structure of data string:

	Single axis unit	Dual axis unit
<b>Baud rate:</b>	2400(*)/9600 baud	2400(*)/9600 baud
<b>Format:</b>	ASCII, 8 data bits, 1 stop bit, no parity	ASCII, 8 data bits, 1 stop bit, no parity
<b>String length:</b>	9 byte	22 byte
<b>Layout:</b>	< D <sub>0</sub> ,D <sub>1</sub> ,D <sub>2</sub> ,D <sub>3</sub> ,D <sub>4</sub> ,D <sub>5</sub> ,D <sub>6</sub> ,D <sub>7</sub> ,D <sub>8</sub> >	< D <sub>0</sub> ... D <sub>21</sub> >
	D <sub>0</sub> = sign(+ or -)	D <sub>0</sub> ... D <sub>8</sub> = "X";"="+"(-)";"xx.xxx"
	D <sub>1</sub> ...D <sub>6</sub> = "xx.xxx"	D <sub>2</sub> = sign (+ or -)
	D <sub>3</sub> = point	D <sub>5</sub> = point
	D <sub>7</sub> =<CR>	D <sub>9</sub> =<CR>
	D <sub>8</sub> =<LF>	D <sub>10</sub> =<LF>
		D <sub>11</sub> ... D <sub>21</sub> = "Y";"="+"(-)";"yy.yyy"
		D <sub>13</sub> = sign (+ or -)
		D <sub>16</sub> = point
		D <sub>20</sub> =<CR>
		D <sub>21</sub> =<LF>

(\*) default value

#### 5.7.4.2 Display sample

##### Inside measurement range

...  
X=+04.475  
Y=-05.875

##### Out of measurement range, overflow

...  
X=+++++++ or X=-----  
Y=+++++++ or Y=-----

## P-Series Inclinometer

### 5.7.4.3 Connection RS 232 interface PC to inclinometer

#### PC side

Sub D-connector 9 pins

#### Plug in connector NS-xx/DMG2-x

7 pin Binder 712-series connector with Meas cable

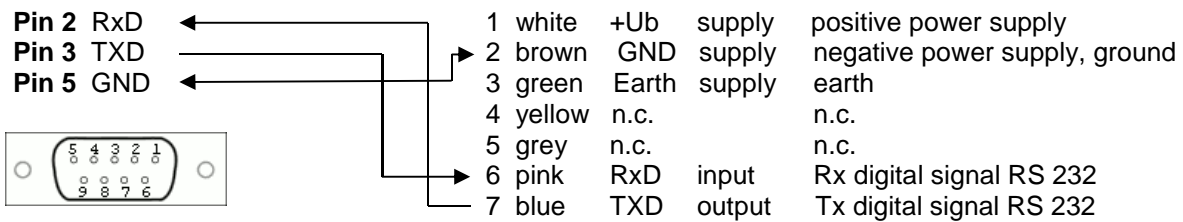

## 5.8 Programming Instructions

The P-series has the possibility to program some parameters to optimize the inclinometer. This programming instruction is valid for single and dual axis P-series.

A standardized RS232 interface is used in duplex mode.

After startup the sensor transmits the angle values in degrees (°) continuously.

### 5.8.1 Commands in user level

Default after power on, running mode.

Commands in user level	Input	Output	Comment
<b>-Setup mode-</b> Stop continuous output of inclination values	"s"	"S"	`s` holding pressed, stops the continuous output of angle results, required for input of commands, terminated by "e" or reset or power on.
-Setup mode- Activate	"P" "prog"	"P?" "P!"	This command is used to activate the setup mode. The password `prog` has to be entered within 3 seconds. If you lose out on, the unit will be going into the running mode.
Command request		"B?"	After received `B?`, choose the single step, baud rate setting, zero setting or close the setup mode.
Exit	"e"	"E!"	To closed the setup mode, press `e` to go into running mode or go to another step.
<b>-Single step mode-</b> Activate	"s"	"S!" "S?"	This command is used to activate the single step mode. Change the continuous output of angle results into polling mode.
Single step activation, off	"0"	CR,LF "B?"	The single step activation will be stopped, off.(default value)
Single step activation, on	"1"	CR,LF B?"	The single step activation will be running, on. Polling mode.
Exit	"e"	"E!"	To closed the single step mode, press `e` to go into single step polling.

## P-Series Inclinometer

Commands in user level	Input	Output	Comment
<b>-Single step polling-</b> Activate	"m"	"M!" "x=xxx.xxx" "y=yyy.yyy"	This command is used to display one measurement value. This command must be replay if another value is needed. To change this mode, start with setup mode.
<b>-Baud rate mode-</b> Activate	"h"	"H!" "H?"	This command is used to activate the baud rate mode to change the baud rate.
Baud rate activation 2400 Baud	"0"	CR,LF "B?"	Input acknowledgment with enter. 2400 Baud (default value)
Baud rate activation 9600 Baud	"1"	CR,LF "B?"	Input acknowledgment with enter to change into 9600 Baud
Exit	"e"	"E!"	To closed the baud rate mode, press `e` to go into running mode or go to another step.
<b>-Zero setting mode-</b> Activate for single axis version	"n" "x"  "n" "x"	"N!" "N?" "Offset=x" "B?"  "N!" "N?" CR,LF "Offset=0" "B?"	This command is used to activate zero setting mode to safe the currently position of the unit. Offset in 1/1000°, x = value <b>Notice:</b> The zero point can be set only if the current angle is between $-5^\circ < x < +5^\circ$ . The command is ignored if the angle is outside the afore mentioned range.  The connection to zero can be cancelled by repeatedly inputting the command `n`, factory default.
Exit	"e"	"E!"	To closed the zero setting mode, press `e` to go into running mode or go to another step.
<b>-Zero setting mode-</b> Activate for dual axis version	"n" "x" "y"  "n" "x" "y"	"N!" "N?" CR,LF "Offset=x" "B?" CR,LF "Offset=y" "B?"  "N!" "N?" CR,LF "Offset=0" "B?" CR,LF "Offset=0" "B?"	This command is used to activate zero setting mode to safe the currently position of the unit. Offset in 1/1000°, x = x-axis value y = y-axis value <b>Notice:</b> The zero point can be set only if the current angle is between $-5^\circ < x,y < +5^\circ$ . The command is ignored if the angle is outside the afore mentioned range.  The connection to zero can be cancelled by repeatedly inputting the command `n`, factory default.
Exit	"e"	"E!"	To closed the zero setting mode, press `e` to go into running mode or go to another step.



## P-Series Inclinometer

### 6 Packaging for Delivery

Safe single package “Blitz Versandbox”, company “Ratioform”, type CVB (150x110x67 mm, for one piece) type will used for the delivery of the product.

The information in this sheet has been carefully reviewed and is believed to be accurate; however, no responsibility is assumed for inaccuracies. Furthermore, this information does not convey to the purchaser of such devices any license under the patent rights to the manufacturer. TE reserves the right to make changes without further notice to any product herein. TE makes no warranty, representation or guarantee regarding the suitability of its product for any particular purpose, nor does TE assume any liability arising out of the application or use of any product or circuit and specifically disclaims any and all liability, including without limitation consequential or incidental damages. Typical parameters can and do vary in different applications. All operating parameters must be validated for each customer application by customer's technical experts. TE does not convey any license under its patent rights nor the rights of others.